

INVERTER GASOLINE GENERATOR OWNER'S MANUAL

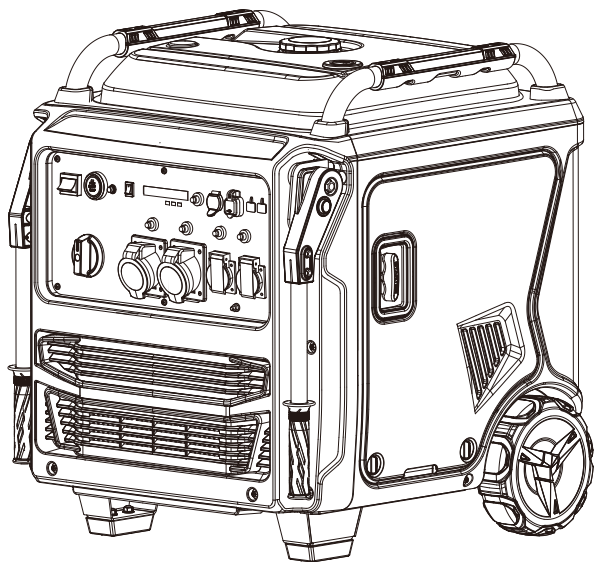

ORIGINAL INSTRUCTION

WE APPRECIATE YOUR BUSINESS

Thank you and congratulations on choosing our product.

This Operating Manual has been designed to instruct you on the correct use and operation of your product. Your satisfaction with this product and its safe operation is our ultimate concern. Therefore please take the time to read the entire manual especially the Safety Precautions. They will help you to avoid potential hazards that may exist when working with this product.



WARNING!

READ AND UNDERSTAND ALL SAFETY PRECAUTIONS IN THIS MANUAL BEFORE OPERATING. FAILURE TO COMPLY WITH INSTRUCTIONS IN THIS MANUAL COULD RESULT IN PERSONAL INJURY, PROPERTY DAMAGE, AND/ OR VOIDING OF YOUR WARRANTY. WILL NOT BE LIABLE FOR ANY DAMAGES DUE TO FAILURE TO FOLLOW THESE INSTRUCTIONS.



Read this manual carefully before operating this generator. This manual should stay with this generator if it is sold.

Note: The pictures in the book are for reference only.

CONTENTS

WE APPRECIATE YOUR BUSINESS	2
IMPORTANT MANUAL INFORMATION	4
IMPORTANT SAFETY INSTRUCTIONS	6
KNOW YOUR GENERATOR	12
GENERATOR PREPARATION.....	16
STARTING YOUR GENERATOR	21
SHUTTING OFF THE GENERATOR.....	23
MAINTENANCE	24
TRANSPORTATION & STORAGE	28
SPECIFICATIONS	30
PRALLEL FUNCTION INSTRUCTIONS	31

IMPORTANT MANUAL INFORMATION

Important information is distinguished in this manual by the following notes.



Symbol Usage

This manual contains important information that you need to know and understand in order to assure YOUR SAFETY and PROPER OPERATION OF EQUIPMENT. The following symbols help you recognize this information. Please read the manual and pay attention to these sections.



WARNING INDICATE A CERTAINTY OR STRONG POSSIBILITY OF PERSONAL INJURY OR DEATH IF INSTRUCTIONS ARE NOT FOLLOWED.

NOTICE

CAUTION INDICATES A POSSIBILITY DAMAGE TO THE PRODUCTS IF INSTRUCTIONS ARE NOT FOLLOWED PROPERLY.



PLEASE READ AND UNDERSTAND THIS MANUAL COMPLETELY BEFORE OPERATING THE MACHINE

IMPORTANT MANUAL INFORMATION

FUEL IS HIGHLY FLAMMABLE AND POISONOUS

- Always turn off the engine when refueling.
- Never refuel while smoking or in the vicinity of an open flame.
- Take care not to spill any fuel on the engine or muffler when refueling.
- If you swallow any fuel, inhale fuel vapor, or allow any to get in your eye(s), see your doctor immediately. If any fuel spills on your skin or clothing, immediately wash with soap and water and change your clothes.
- When operating or transporting the machine, be sure it is kept upright. If it tilts, fuel may leak from the carburetor or fuel tank.

EXHAUST FUMES ARE POISONOUS

- Never operate this product in a closed area or it may cause unconsciousness and death within a short time. Always operate this product in a well ventilated outdoor area.

ENGINE AND MUFFLER MAY BE HOT

- When operating the generator place in a safe area away from pedestrians or children.
- Avoid placing any flammable materials near the exhaust outlet during operation.
- Keep the generator at least 1m(3 ft) from buildings or other equipment, or the product may overheat.
- Do not operate the product with a dust cover, or other objects covering it.
- When covering the generator, be sure to do so only after the engine and muffler have completely cooled down.
- Be sure to carry the generator only by its carrying handles.
- Do not place any obstacles on the generator.

TO PREVENT ELECTRIC SHOCK

- Never operate the product in rain or snow.
- Never touch the generator with wet hands or electrical shock can occur.

IMPORTANT SAFETY INSTRUCTIONS

CORRECT USAGE WARNING

Example location to reduce risk of carbon monoxide poisoning

- ONLY use outside and downwind, far away from windows, doors and vents.
- Direct exhaust away from occupied spaces.



NEVER use inside a home or garage, EVEN IF doors and windows are open.

Only use OUTSIDE and far away from windows, doors, and vents.

INCORRECT USAGE WARNING

Do not operate in any of the following locations:

- Near any door, window or vent
- Garage
- Basement
- Crawl Space
- Living Area
- Entry Way
- Porch
- Mudroom

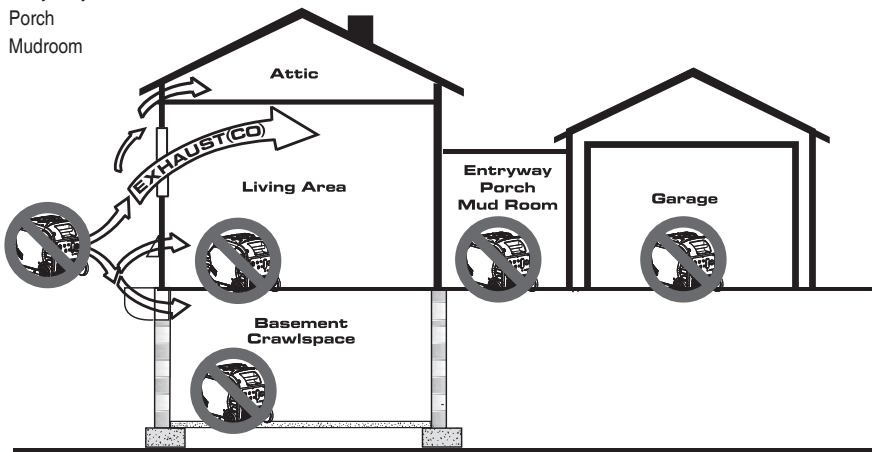

IMPORTANT SAFETY INSTRUCTIONS

WARNING



Starter cord kickback (rapid retraction) will pull hand and arm toward engine faster than you can let go which could cause broken bones, fractures, bruises, or sprains resulting in serious injury.

- When starting engine, pull cord slowly until resistance is felt and then pull rapidly to avoid kickback.
- **NEVER** start or stop engine with electrical devices plugged in and turned on.

WARNING



Fuel and its vapors are extremely flammable and explosive which could cause burns, fire, or explosion resulting in death or serious injury and/or property damage.

WHEN ADDING OR DRAINING FUEL

- Turn generator engine OFF and let it cool at least 2 minutes before removing fuel cap. Loosen cap slowly to relieve pressure in tank.
- Fill or drain fuel tank outdoors.
- **DO NOT** overfill tank. Allow space for fuel expansion.
- If fuel spills, wait until it evaporates before starting engine.
- Keep fuel away from sparks, open flames.
- Check fuel lines, tank, cap, and fittings.
- **DO NOT** light a cigarette or smoke.

WHEN STARTING EQUIPMENT

- Ensure spark plug, muffler, fuel cap, and air cleaner are in place.
- **DO NOT** crank engine with spark plug removed.



Read Owner's Manual before operation.



You CAN be KILLED or SERIOUSLY HURT if you don't follow instructions.

WHEN OPERATING EQUIPMENT

- **DO NOT** operate this product inside any building, carport, porch, mobile equipment, marine applications, or enclosure.
- **DO NOT** tip engine or equipment at angle which causes fuel to spill.
- **DO NOT** stop engine by moving choke control to "Start" position.

WHEN TRANSPORTING, MOVING OR REPAIRING EQUIPMENT

- Transport/move/repair with fuel tank EMPTY or with fuel shutoff valve OFF.
- **DO NOT** tip engine or equipment at angle which cause fuel to spill.
- Disconnect spark plug wire.

WHEN STORING FUEL OR EQUIPMENT WITH FUEL IN TANK

- Store away from furnaces, stoves, water heaters, clothes dryers, or other applications that have pilot light or other ignition source because they could ignite fuel vapors.

WARNING

- This generator does not meet U.S. Coast Guard Regulation 33CFR-183 and should not be used on marine applications.
- Failure to use the appropriate U.S. Coast Guard approved generator could result in death or serious injury and/or property damage.

WARNING



Generator voltage could cause electrical shock or burn resulting in death or serious injury.

- Use approved transfer equipment, suitable for the intended use, to prevent backfeed by isolating generator from electric utility workers.

IMPORTANT SAFETY INSTRUCTIONS

- When using generator for backup power, notify utility company.
- Use a ground fault circuit interrupter (GFCI) in any damp or highly conductive area, such as metal decking or steel work.
- **DO NOT** touch bare wire or receptacles.
- **DO NOT** use generator with electrical cords which are worn, frayed, bare or otherwise damaged.
- **DO NOT** operate generator in the rain or wet weather.
- **DO NOT** handle generator or electrical cords while standing in water, while barefoot, or while hands or feet are wet.
- **DO NOT** allow unqualified persons or children to operate or service generator.

⚠ WARNING



Exhaust heat/gases could ignite combustibles, structures or damage fuel tank causing a fire, resulting in death or serious injury and/or property damage. Contact with muffler area could cause burns resulting in serious injury.

- **DO NOT** touch hot parts and **AVOID** hot exhaust gases.
- Allow equipment to cool before touching.
- It is violation of California Public Resource Code, Section 4442, to use or operate the engine on any, forest-covered, brush-covered, or grass-covered land unless the exhaust system is equipped with a spark arrester, as defined in Section 4442, maintained in effective working order. Other states or federal jurisdictions may have similar laws. Contact the original equipment manufacturer, retailer, or dealer to obtain a spark arrester designed for the exhaust system installed on this engine.
- Replacement parts must be the same and installed in the same position as the original parts.

⚠ WARNING



Uninstall sparking could cause fire or electric shock resulting in death or serious injury.

WHEN ADJUSTING OR MAKING REPAIRS TO YOUR GENERATOR

- Disconnect the spark plug wire from the spark plug and place the wire where it cannot contact spark plug.

WHEN TESTING FOR ENGINE SPARK

- Use approved spark plug tester.
- **DO NOT** check for spark with spark plug removed.

⚠ WARNING



Starter and other rotating parts could entangle hands, hair, clothing, or accessories resulting in serious injury.

- **NEVER** operate generator without protective housing or covers.
- **DO NOT** wear loose clothing, jewelry or anything that could be caught in the starter or other rotating parts.
- Tie up long hair and remove jewelry.

⚠ WARNING

Excessively high operating speed could result in minor injury. Excessively low operating speed impose a heavy load.

- **DO NOT** tamper with governors spring, link or other parts to increase engine speed. Generator supplies correct rated frequency and voltage when running at governed speed.
- **DO NOT** modify generator in any way.

NOTE:

Exceeding generator wattage/amperage capacity could damage generator and/or electric devices connected to it.

- **DO NOT** exceed the generator's wattage amperage capacity.
- Start generator and let engine stabilize before connecting electrical loads.
- Connect electrical loads in OFF positions, then turn ON for operation.
- Turn electrical load OFF and disconnect from generator before stopping generator.

IMPORTANT SAFETY INSTRUCTIONS

NOTE:

Improper treatment of generator could damage it and shorten its life.

- Use generator only for intended uses.
- If you have questions about intended use, ask dealer or contact local service center.
- Operate generator only on level surfaces.
- **DO NOT** expose generator to excessive moisture, dust, dirt, or corrosive vapors.
- **DO NOT** insert any objects through cooling slots.
- If connected devices overheat, turn them off and disconnect them from generator.
- Shut off generator if:
 - Electrical output is lost.
 - Equipment sparks, smokes, or emits flames.
 - Unit vibrates excessively

WARNING

Medical and Life Support Uses.

- In case of emergency, call fire alarm call number immediately
- NEVER use this product to power life support devices or life support appliances.
- NEVER use this product to power medical devices or medical appliances.
- Inform your electrical provider immediately if you or anyone in your household depends on electrical equipment to live.
- Inform your electrical provider immediately if a loss of power would cause you or anyone in your household to experience a medical emergency.

WARNING:

Don't use this generator to supply a building wiring system.

- Do not use this generator to provide power for emergency medical equipment or life support devices.
- Exhaust contains poisonous carbon monoxide, a colorless, odorless gas. Breathing exhaust can cause loss of consciousness and can lead to death. If running in a confined or partial-enclosed area, the air may contain a dangerous amount of carbon monoxide. To keep exhaust fumes from building up, always provide adequate ventilation.
- Always use a battery-powered carbon monoxide detector when running the generator. IF you begin to feel sick, dizzy, or weak while using the generator, shut it off and get to fresh air immediately. See a doctor. You may have carbon monoxide poisoning.
- Place the generator on a flat, stable surface with a slope of no more than 4°.
- Operate outdoors in a well-ventilated, well-lit area isolated from working areas to avoid noise interference.
- Operating the generator in wet conditions could result in electrocution. Keep the unit dry. Keep the generator a minimum of 3 feet away from all types of combustible material.
- Do not operate generator near hazardous material.
- Do not operate generator at a gas or natural gas filling station.
- Do not touch the muffler or cylinder during or immediately after use; they are HOT and will cause burn injury.
- This generator has a neutral floating condition. This means the neutral conductor is not electrically connected to the frame of the machine. Do not allow the generator's gas tank to overflow when filling. Fill to 1 in. Below the top neck of the gasoline tank to allow for fuel expansion. Do not cover the fuel tank cap when the engine is running. Covering the fuel tank cap during use may cause engine failure and/or damage to the tool.

IMPORTANT SAFETY INSTRUCTIONS

- Do not smoke when filling the generator with gasoline.
- Shut down the engine and allow to cool completely before adding gasoline or lubricant to the generator.
- Do not remove the oil dipstick or the fuel tank cap when the engine is running.
- Pay close attention to all safety labels located on the generator.
- Keep children a minimum of 10 feet away from the generator at all times.
- The unit operates best in temperatures between 23°F and 104°F with a relative humidity of 90% or less.
- Operating voltage and frequency requirement of all electronic equipment should be checked prior to plugging them into this generator. Damage may result if the equipment is not designed to operate within a +/- 10% voltage variation, and +/- 3 hz frequency variation from the generator name plate ratings.
- For outdoor use only.
- Save these instructions. Refer to them frequently and use them to instruct others who may use this product. If you loan someone this product, loan them these instructions also.

SIGNAL DESCRIPTION

The following signal words and meanings are intended to explain the levels of risk associated with this product.

SIGNAL	MEANING
DANGER:	Indicates an imminently hazardous situation, which, if not avoided, will result in death or serious injury.
WARNING:	Indicates a potentially hazardous situation, which, if not avoided, could result in death or serious injury.
CAUTION:	Indicates a potentially hazardous situation, which, if not avoided, may result in minor or moderate injury.
NOTICE:	(Without Safety Alert Symbol) Indicates important information not related to an injury hazard, such as a situation that may result in property damage.

GROUNDING



Properly ground generator to prevent electric shock.

- Connect the ground terminal of the generator to the ground electrode buried in the ground.

WARNING NOTES

- Failure to properly ground the generator can result in electric shock.
- Be sure to always comply with electric loads.

IMPORTANT SAFETY INSTRUCTIONS

CONNECTION



Do not connect to a building's electrical system unless an isolation switch has been installed by a qualified electrician.

Connections for standby power to a building's electrical system must be made by a qualified electrician and must comply with all applicable laws and electrical codes. Improper connections can allow electrical current from the generator to back feed into the utility lines. Such back feed may electrocute utility company workers or others who contact the lines during a power outage, and when utility power is restored, the generator may explode, burn, or cause fires in the building's electrical system.



Always use proper approved electrical cords. Be sure to comply with all electric codes. Do not use electrical cords that are worn or damaged.

Always use proper approved transfer switch to isolate generator from the electric panel.

LABEL

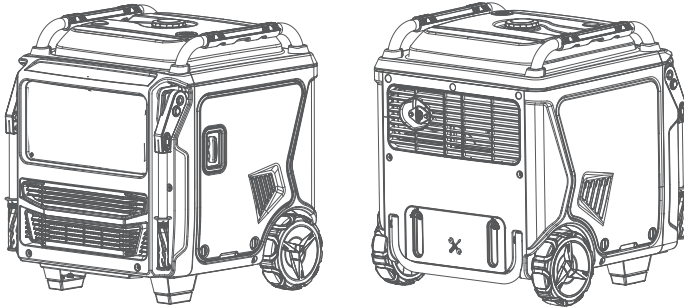

1



No touching

2



Read Manufacturer's Instructions

Asphyxiation Hazard

Fire Hazard

Electrical Shock Hazard

Warning: Prohibited for indoor use

3



Start label

KNOW YOUR GENERATOR

1. Discription

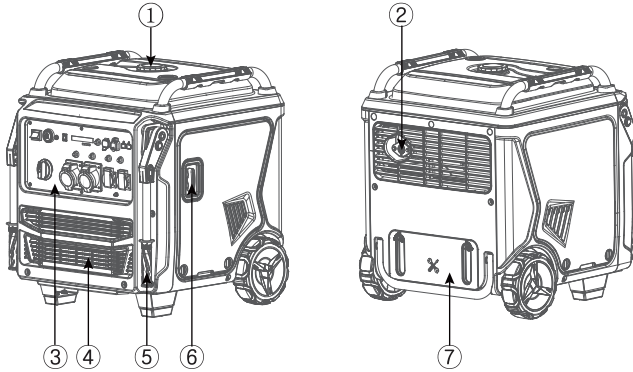

① **Fuel tank cap**

② **Muffler**

Avoid contact until the engine is cooled down. The spark arrestor prevents sparks from exiting the muffler. It must be removed for servicing.

③ **Control panel**

Contains the reset breaker, outlets and warning lights.

④ **Cooling air inlet**

Helps move airflow in unit to regulate engine temperatures.

⑤ **Carrying handle**

⑥ **Recoil starter**

Pull to start the engine.

⑦ **Tool box**

KNOW YOUR GENERATOR

2. Control Panel

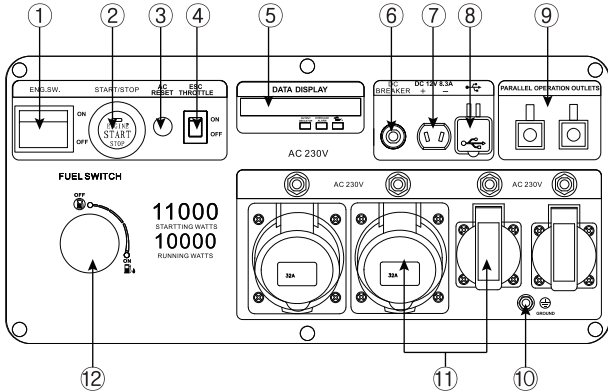



- ① Engine switch
- ② Electric start button
- ③ AC reset
- ④ ESC
- ⑤ LCD display
- ⑥ DC protector
- ⑦ DC socket
- ⑧ USB
- ⑨ Parallel connection
- ⑩ Ground terminal
- ⑪ AC receptacle
- ⑫ Fuel switch

(This figure is for reference only).

KNOW YOUR GENERATOR

3. Control function

3.1 Multi-Switch/Fuel Switch

1.  Ignition circuit is switched off. Fuel is switched off. The engine will not run.
2.  Ignition circuit is switched on. Fuel is switched on. Choke is switched on. The engine can be running.

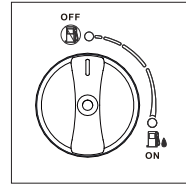

3.2 Low Oil Alarm(Red)

When the oil level falls below the lower level, the low oil alarm comes on and then the engine stops automatically. The engine will not start until oil is added to the unit to bring it up to the appropriate level.

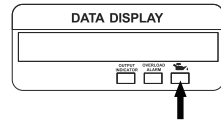

3.3 Overload Alarm(Red)

The overload alarm comes on when a connected device requires more power than the generator can produce. The output indicator(Green) will go off and the overload alarm(Red) will stay on, but the engine will continue to run.

When the overload indicator light comes on and power generation stops, proceed as follows:

1. Turn off any connected electric devices and stop the engine.
2. Reduce the total wattage of connected electric devices within the rated output.
3. Checking cooling air inlet for any blockage, remove it if had.
4. After checking, restart the engine.

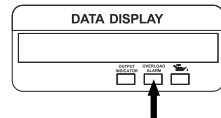

3.4 Output Indicator(Green)

The output indicator comes on when the engine start and produces power.

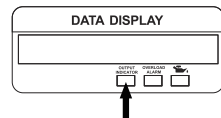

KNOW YOUR GENERATOR

3.5 Engine smart control (ESC)

“ON”

When the ESC switch is turned to “ON”, the throttle controls the engine speed according to the connected load. The results are better fuel consumption and less noise.

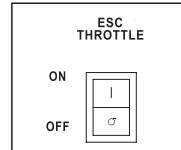

“OFF”

When the ESC switch is turned to “OFF”, the engine runs at the rated r/min regardless of whether a load is connected or not.

NOTICE:

The ESC must be turned to “OFF” when using electric devices that require a large starting electric current.

3.6 Fuel tank cap

Remove the fuel tank cap by turning it counter clockwise.

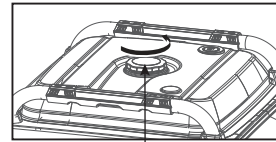

Fuel Cap

3.7 Ground (Earth) terminal

Ground (Earth) terminal connects the earth line to prevent electrical shock.

When the electric device is earthed, always the generator must be earthed.

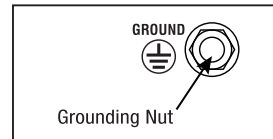

GENERATOR PREPARATION

BEFORE STARTING THE INVERTER



BEFORE STARTING THE INVERTER, REVIEW SAFETY SECTION STARTING ON PAGE 5.

Location Selection – Before starting the inverter, avoid exhaust and location hazards by verifying:

- You have selected a location to operate the inverter that is outdoors and well ventilated.
- You have selected a location with a level and solid surface on which to place the inverter.
- You have selected a location that is at least 6 feet (1.8 m) away from any building, other equipment or combustible material.
- If the inverter is located close to a building, make sure it is not located near any windows, doors and/or vents.

⚠ DANGER

Using a generator indoors **CAN KILL YOU IN MINUTES.** Generator exhaust contains carbon monoxide. This is a poison you cannot see or smell.



NEVER use inside a home or garage, **EVEN IF** doors and windows are open.



Only use **OUTSIDE** and far away from windows, doors, and vents.

Avoid other generator hazards. **READ MANUAL BEFORE USE.**

⚠ WARNING



Always operate the inverter on a level surface. Placing the inverter on non level surfaces can cause the inverter to tip over, causing fuel and oil to spill. Spilled fuel can ignite if it comes in contact with an ignition source such as a very hot surface.

NOTICE

Only operate the inverter on a solid, level surface. Operating the inverter on a surface with loose material such as sand or grass clippings can cause debris to be ingested by the inverter that could:

- Block cooling vents
- Block air intake system

Weather – Never operate your inverter outdoors during rain, snow or any combination of weather conditions that could lead to moisture collecting on, in or around the generator.

Dry Surface – Always operate the inverter on a dry surface free of any moisture.

No Connected Loads – Make sure the inverter has no connected loads before starting it. To ensure there are no connected loads, unplug any electrical extension cords that are plugged into the control panel receptacles.

NOTICE

Starting the inverter with loads already applied to it could result in damage to any appliance being powered off the inverter during the brief start-up period.

Grounding the Inverters

Consult with your local municipalities for your grounding codes.

⚠ WARNING



Be sure the inverter is properly connected to earth ground before operating.

POWERCORD

Using Extension Cords

Portable Power assumes no responsibility for the contents of this table. The use of this table is solely the responsibility of the user only. This table is intended for reference only. The results produced by using this table are not guaranteed to be correct or applicable in all situations as the type and construction of the cords are highly variable. Always check with local regulations and a licensed electrician prior to installing or connecting an electrical appliance

AMPS	Extension Cord Wire Gauge Size										
	10	20	30	40	50	60	80	100	120		
5	20	18	16	14	12	12	10	10	8		
10	18	16	14	12	12	10	10	8	8		
15	16	14	12	12	10	10	8	8	6		
20	14	12	12	10	10	8	8	6	6		
25	12	12	10	10	8	8	6	6	6		
30	12	10	10	8	8	6	6	6	6		
35	10	10	8	8	6	6	6	6	6		

GENERATOR PREPARATION

The following section describes the necessary steps to prepare the generator for use. Failure to perform these steps properly can damage the generator or shorten its life.

STEP 1 - ADD/CHECK OIL

The generator is shipped without oil. User must add the proper amount of oil before operating the generator for the first time. The oil capacity of the engine crankcase is **1.4L**.

To add oil, follow these steps:

1. Place the generator on a level surface. Make sure the engine is OFF before adding or checking oil.

CAUTION: Keep the generator level! Tilting the generator to assist in filling will cause oil to flow into the wrong areas of the engine and cause damage.

2. Turn the oil access cover knob clockwise, and remove the cover from the side panel. Unscrew the oil dipstick from the engine.
3. Using an oil funnel or appropriate dispenser, slowly add oil into the oil fill, being careful not to overfill the unit. Fill the crankcase to the upper fill line so you can visually see the oil coming halfway up the oil fill threads.
4. Reinstall the oil dipstick and firmly tighten it. Wipe clean any spilled oil.
5. Reinstall the oil access cover. Turn the oil access cover knob counter clockwise to the locked position to secure the cover in place.

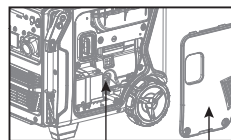

Oil dipstick

Cover

NOTE: Used engine oil should be disposed of at an approved disposal site. See local retailer for more information.

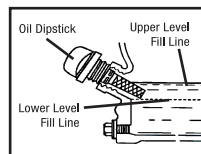
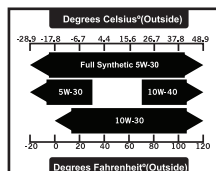

NOTE: SAE 10W-30 is recommended for general use. Other viscosities shown in the chart may be used when the average temperature in your area is within the indicated range.

For subsequent operation, the oil level should be checked before each use, or after every 8 hours of operation. The generator is equipped with a low-oil sensor and will NOT start without a sufficient amount of oil.

To check oil level (before every subsequent start):

1. Place the generator on a level surface. Make sure the engine is OFF before adding or checking oil.
2. Open the oil access cover. Remove and wipe the dipstick with a clean rag.
3. Insert the dipstick into the oil fill without screwing it in. Remove the dipstick to check the oil mark. If the oil mark covers less than one half of the dipstick, slowly add oil until you can see the oil coming halfway up the oil fill threads.
4. Wipe clean any oil leaks and firmly tighten the dipstick. Reinstall the oil access cover.

GENERATOR PREPARATION

STEP 2 - ADD/CHECK FUEL

⚠ GASOLINE WARNING: Keep generator away from open flame. This generator may emit highly flammable and explosive gasoline vapors, which can cause severe burns or even death if ignited. A nearby open flame can lead to explosion even if not directly in contact with gasoline

- Do not operate near open flame, heat, or any other ignition source.
- Do not smoke near the generator.
- Always operate on a firm, level surface.
- Always turn generator off before refueling. Allow generator to cool for at least 2 minutes before removing the fuel cap. Loosen cap slowly to relieve pressure in tank.
- Do not overfill fuel tank. Fuel may expand during operation. Do not fill to the top of the tank. Allow for expansion.
- Always check for spilled fuel before operating. Clean up any spilled fuel before starting.
- Empty fuel tank before storing or transporting the generator to prevent spilling.

Use **ONLY** fresh (within 30 days from purchase), lead-free gasoline with a **minimum of 87 octane rating**. The generator performs best with ethanol-free gasoline. **DO NOT** use gasoline with over 10% ethanol. The capacity of the fuel tank is **32L**. **DO NOT** mix oil with gasoline.

NOTICE:

- Never use an oil/gasoline mixture.
- Never use old gasoline.
- Keep gasoline away from sparks, open flames, pilot lights, heat and other sources of ignition.
- Avoid getting dirt or water into the fuel tank.
- Gasoline can age in the tank and make starting difficult. Never store generator for more than 2 months with fuel in the tank.

To add gasoline, follow these steps:

1. Make sure the generator is shut OFF and on a level surface. Unscrew the fuel cap and set it aside. The fuel cap may be tight and hard to unscrew.

2. Slowly add unleaded gasoline to the fuel tank. Be careful not to overfill.

NOTE: Do not fill the fuel tank to the very top. If you do so, gasoline will expand and spill during use, even with the fuel cap in place.

3. Reinstall fuel cap and wipe clean any spilled gasoline with a dry cloth.

To check fuel level:

Check the fuel gauge for fuel level. If the fuel level is low, refill the fuel tank before starting your generator for the next time.

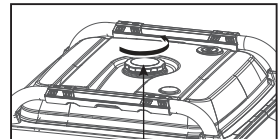

Fuel Cap

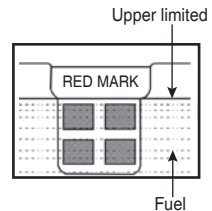

STEP 3 - CONNECT THE BATTERY

⚠ WARNING: BATTERY GIVES OFF EXPLOSIVE HYDROGEN GAS.

- Keep battery away from sparks, cigarettes, or other sources of flame.
- Do not connect or disconnect battery while generator is running.
- Service or use battery only in well ventilated areas.

GENERATOR PREPARATION

⚠ WARNING: Battery contains sulfuric acid. Battery acid is poisonous. Tilting the generator with the battery installed can cause battery acid to spill.

- Wear protective clothing and eye wear when servicing battery.
- Keep out of reach of children.
- If battery acid gets on your skin, wash with water immediately.
- If battery acid gets in your eyes, flush with water for at least 15 minutes and call a doctor immediately. If battery acid is swallowed, call a doctor immediately. Drink a large amount of water or milk. Then drink milk of magnesia or vegetable oil.

The generator is shipped with the lithium-ion battery's negative (-) terminal disconnected to maximize safety. To start the generator using electric start, the battery must be connected.

To connect the battery:

For the first use, remove the maintenance cover on the side of the recoil starter handle. Then connect the battery line. Be noted that DISCONNECTING the battery line if NO USE for long time.

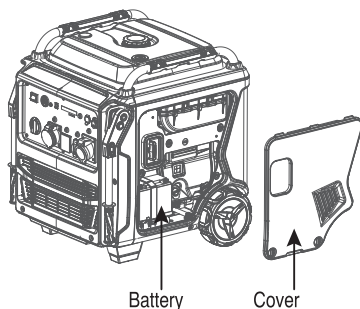

NOTICE: If you do not plan to use the generator for a long period of time, we recommend to DISCONNECT the negative battery cable from the battery to protect the battery from losing charge. After disconnecting the cable, cover the free end with an insulator such as electrical tape. You may also choose to use a trickle charger (not included) to maintain battery charge.

STEP 4 - GROUND THE GENERATOR

To reduce the risk of electric shock and to maximize safety, the generator should be properly grounded.

Ground the generator by tightening the grounding nut on the front control panel against a grounding wire. A generally acceptable grounding wire is a **No.12 AWG (American Wire Gauge) stranded copper wire**.

This grounding wire should be connected at the other end to a copper, brass, or steel grounding rod that is driven into the earth. Wire and grounding rods are not included with the generator.

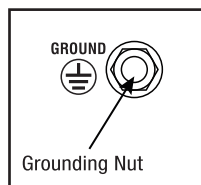

NOTE: Grounding codes can vary by location. Contact a local electrician to check the area codes.

⚠ WARNING: Failure to properly ground the generator increases your risk of electric shock.

GENERATOR PREPARATION

HIGH ALTITUDE OPERATION ABOVE 3000 FEET

The fuel system on this generator may be affected by operation at high altitudes. Proper operation can be ensured by installing an altitude kit at altitudes higher than 3000 feet above sea level. At elevations above 8000 feet, the engine may experience a decrease in performance, even with the proper altitude kit. Operating this generator without said kit may increase the engine's emissions and decrease both fuel economy and performance. Please contact your authorized service center for important information regarding these modifications.

Before starting the generator, make sure you have read and performed the steps in the "Generator Preparation" section of this manual. If you are unsure about how to perform any of the steps in this manual Please contact your authorized service center

DANGER: CARBON MONOXIDE

Using a generator indoors **CAN KILL YOU IN MINUTES**. Generator exhaust contains carbon monoxide (CO). This is a poison gas you cannot see or smell. If you can smell the generator exhaust, you are breathing CO. But even if you cannot smell the exhaust, you could be breathing CO.

NEVER use a generator inside homes, garages, crawl spaces, or other partially enclosed areas. Deadly levels of carbon monoxide can build up in these areas. Using a fan or opening windows and doors does NOT supply enough fresh air. ONLY use a generator OUTSIDE and far away from windows, doors, and vents. These openings can pull in generator exhaust.

Even if you use a generator correctly, CO may leak into the home. ALWAYS use a battery-powered or battery-backup CO alarm in the home. If you start to feel sick, dizzy, or weak after the generator has been running, move to fresh air RIGHT AWAY. See a doctor. You may have carbon monoxide poisoning.

 **WARNING:** The exhaust from this product contains chemicals known to the State of California to cause cancer, birth defects, or other reproductive harm.

 **WARNING:** DO NOT operate generator near open flame or flammable materials This generator may emit highly flammable and explosive gasoline vapors, which can cause severe burns or even death if ignited. A nearby open flame can lead to explosion even if it isn't directly in contact with gasoline. Do not smoke near the generator.

 **WARNING:** This generator produces powerful voltage, which can result in electrocution.

 **WARNING:** Do not use in rainy or wet conditions. Do not touch bare wires or receptacles (outlets). Do not allow children or non-qualified persons to operate.

 **WARNING:** Generator should ONLY be connected to electrical devices, either directly or with an extension cord. NEVER CONNECT TO A BUILDING ELECTRICAL SYSTEM without a qualified electrician and connected to a transfer switch as a separately derived system. Such connections must comply with local electrical laws and codes. Failure to comply can create a back-feed, which may result in serious injury or death to utility workers.

To maximize safety, ALWAYS ground the generator before using it (see the "GROUND THE GENERATOR" section on page 15).

Use a ground fault circuit interrupter (GFCI) in highly conductive areas such as metal decking or steel work. GFCIs are available in-line with some extension cords.

CAUTION: Disconnect all electrical loads from the generator before attempting to start.

STARTING YOUR GENERATOR

Before starting the generator:

1. Verify that the generator is outside on a dry, level surface. Allow at least two feet of clearance on all sides of the generator.
2. To maximize safety, check that the generator is properly grounded (see “GROUND THE GENERATOR”).
3. Check there is sufficient level of oil in the crankcase. Add oil if necessary (see “ADD/CHECK OIL”).
4. Make sure there is sufficient level of gasoline in the fuel tank. Add fuel if necessary (see “ADD/CHECK FUEL”).
5. Make sure all electrical devices are unplugged from the generator during ignition. Otherwise it will be difficult for the engine to start.

To start the generator, perform the following steps:

Turn the switch to “ON” position.

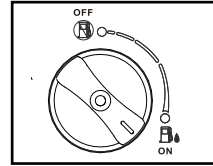

Turn the switch to “ON” position.

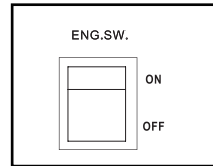

Manual start:

1. Turn the ESC throttle to the “ON” position.
2. Place one hand on the generator to hold it place, and pull on the recoil starter handle slowly until a slight resistance is felt. Then pull quickly to start the engine. Return cord gently into the machine. Never allow the cord to snap back.

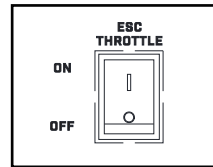

Electrical start:

1. Turn the ESC throttle to the “ON” position.
2. Hold down the ENGINE START switch for 1-2 seconds.

NOTE: If the engine does not start, release the switch and try again. Keeping the switch in the START position too long can damage the starter.



STARTING YOUR GENERATOR

Turn the Fuel switch to “ON” position.

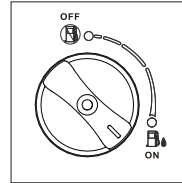

Indicator light turns green.

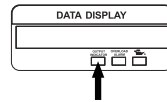

NOTE: If you have repeated failed attempts to start the engine, please consult the troubleshooting guide.

Allow the generator to run for several minutes before attempting to connect any electrical devices. This allows the generator to stabilize its speed and temperature.

SHUTTING OFF THE GENERATOR

⚠ CAUTION: Unplugging running devices can cause damage to the generator. Never stop the engine with electrical devices connected and running.

1. Turn off all electrical devices prior to unplugging them from the generator. Unplugging running devices can cause damage to the generator.
2. Allow generator to run at no load for a few minutes to stabilize internal temperatures.
3. Turn the Multi-switch to the "OFF" position to shut down the engine and fuel.

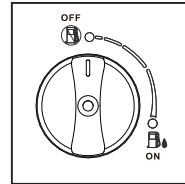

⚠ WARNING: Allow the generator to cool down before touching areas that become hot during use.

CAUTION: Allowing gasoline to sit in the fuel tank for long periods of time can make it difficult to start the generator in the future. NEVER store the generator for extended periods of time (over 2 months) with fuel in the fuel tank. Refer to "STORING THE GENERATOR".

MAINTENANCE



BEFORE PERFORMING MAINTENANCE ON THE INVERTER, REVIEW THE SAFETY SECTION STARTING ON PAGE 5, AS WELL AS THE FOLLOWING SAFETY MESSAGES.

⚠ WARNING	
	Avoid accidentally starting the inverter during maintenance by removing the spark plug boot from the spark plug. For electric start inverters, also disconnect the battery cables from the battery (disconnect the black negative (-) cable first) and place the cables away from the battery posts to avoid arcing.
	Allow hot components to cool to the touch prior to performing any maintenance procedure.
	Internal pressure can build in the engine crankcase while the engine is running. Removing the oil fill plug/dipstick while the engine is hot can cause extremely hot oil to spray out of the crankcase and can severely burn skin. Allow engine oil to cool for several minutes before removing the oil fill plug/dipstick.
	Always perform maintenance in a well-ventilated area. Gasoline fuel and fuel vapors are extremely flammable and can ignite under certain conditions.

⚠ CAUTION	
	Avoid skin contact with engine oil or gasoline. Prolonged skin contact with engine oil or gasoline can be harmful. Frequent and prolonged contact with engine oil may cause skin cancer. Take protective measures and wear protective clothing and equipment. Wash all exposed skin with soap and water.

⚠ WARNING	
	Failure to perform periodic maintenance or not following maintenance procedures can cause the inverter to malfunction and could result in death or serious injury.

NOTICE	
Periodic maintenance intervals vary depending on inverter operating conditions. Operating the inverter under severe conditions, such as sustained high-load, high-temperature, or unusually wet or dusty environments, will require more frequent periodic maintenance. The intervals listed in the maintenance schedule should be treated only as a general guideline.	

Following the maintenance schedule is important to keep the inverter in good operating condition. The following is a summary of maintenance items by periodic maintenance intervals.

Recommended Maintenance Schedule		Each 8 hours or daily	First 25 hours	Every 3 months or 50 hours	Every 6 months or 100 hours	Before Storage	As necessary
Engine Oil	Check level	x					
	Replace		x*	x*		x	x
Air Filter	Check			x*			
	Clean			x*			
Spark Plug	Check/clean/regap				x		
	Change						x
Fuel Tank	Check level	x					
	Drain					x	x
Carburetor (Auto Shutoff)	Drain					x	x
Carburetor (Manual Shutoff)		x				x	
Spark Arrestor	Check/Clean				x		
Battery	Disconnect					x	

* Clean/change more often under dusty conditions or operating under heavy load.

MAINTENANCE

IMPORTANT GENERATOR MAINTENANCE TIPS:

- Drain your carburetor after each use and before storage to prevent it from clogging.
- Do not store the generator with fuel inside the tank for more than 2 months - the fuel will go bad.
- Run the generator for at least 20 minutes every month to charge the battery and maximize the generator's lifespan.

NOTE: Failure to properly maintain the generator will void the warranty.

AIR FILTER MAINTENANCE

Check every 50 hours of operation (refer to Recommended Maintenance Schedule).

Routine maintenance of the air filter helps maintain proper airflow to the carburetor. Occasionally check that the air cleaner is free of excessive dirt.

To inspect and clean the air filter:

1. Unscrew the maintenance cover bolts, and remove the cover from the side panel.
 2. Take the cover off of the air cleaner. Remove the sponge-like air filter element from the casing. Wipe excessive oil and any dirt from inside of the air filter casing.
 3. Check and clean the foam air filter element. Good elements can be washed in soapy water. Dry the element in clean cloth (do not twist it). Add a few drops of engine oil to the air filter element and spread it evenly.
- If the air filter element has been damaged, replace it with a new one. Please contact your authorized service center.
4. Reinstall the air filter element, air filter cover and maintenance cover.

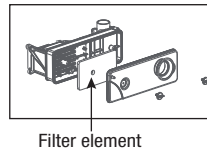
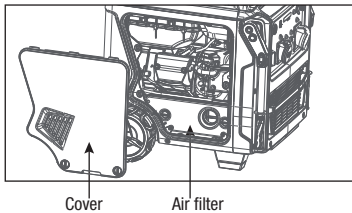

⚠ WARNING: Running the engine with a dirty, damaged or missing air filter element can result in danger to the operator and cause the engine to wear out prematurely.

SPARK PLUG MAINTENANCE

Refer to Recommended Maintenance Schedule for maintaining the spark plug.

The spark plug must be properly gapped and free of deposits in order to ensure proper engine operation. If the engine is hot, allow it to cool before servicing the spark plug.

MAINTENANCE

To inspect or replace the spark plug:

1. Unscrew the maintenance cover knob, and remove the cover from the side panel.
2. Remove the spark plug cap.
3. Use the included spark plug wrench to unscrew and then carefully remove the spark plug from the engine.

TIP: There is limited space for the wrench to turn. Use both rows of holes in the spark plug wrench to gain leverage to loosen the plug.

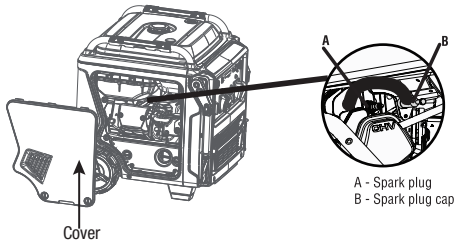

4. Visually inspect the spark plug. If it is cracked or chipped, or if the electrodes are worn or burned, discard it and replace with a new spark plug.

5. If re-using the spark plug, use a wire brush to clean any dirt from around the spark plug base, then re-gap the spark plug.

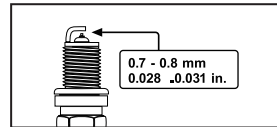

6. Measure the plug gap with a spark plug gap gauge. The gap should be 0.7 - 0.8 mm (0.028 - 0.031 in). Carefully adjust the gap if necessary.

7. Screw the spark plug back into the spark plug hole using the spark plug wrench. Do not over-tighten spark plug. Recommended tightening of spark plug is $\frac{1}{2}$ to $\frac{3}{4}$ of a turn (15 ft-lb torque/20.33 Nm) after spark plug gasket contacts spark plug hole.

8. Reinstall the spark plug cap and maintenance cover.

SPARK ARRESTOR MAINTENANCE

Inspect and clean the spark arrester every 100 hours of operation.

The spark arrester is located outside the muffler, which gets very hot during operation. Allow the engine to cool completely before servicing the spark arrester. To inspect and clean the spark arrester:

1. Remove the two screws, and remove the tail pipe and spark arrester.
2. Use a brush to remove carbon deposits from the spark arrester screen. Be careful to avoid damaging the screen.

The spark arrester must be free of breaks and tears. Replace the spark arrester if it is damaged.

3. Install the spark arrester in the reverse order of removal.

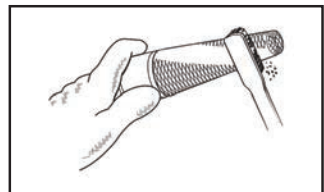

DRAINING THE FUEL TANK / CARBURETOR

To help prevent gum deposits in the fuel system, drain the fuel from the tank and carburetor before storing.

1. With the help of another person, place the generator on an elevated platform such as a table or desk.

MAINTENANCE

2. Unscrew the maintenance cover bolts, and remove the cover from the side panel.

To draining fuel tank:

3.1 Make sure that the fuel switch or multi-switch to turned to "ON".

To draining carburetor:

3.2 Make sure that the fuel switch or multi-switch to turned to "OFF", at this position, the fuel valve is turned OFF so that only the fuel left inside the carburetor will be drained out.

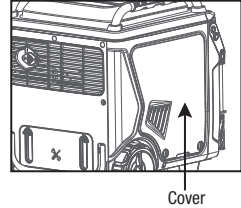

4. The carburetor can be accessed between the engine and the air filter. Locate the transparent tube from the carburetor that extends down through the base plate of the generator.

5. Prepare an approved gasoline-storage container and direct the end of the drain tube into the container.

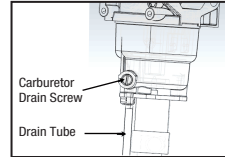

6. Open up the carburetor drain screw with a flat-head screwdriver (not included) and drain out any gasoline that has built up inside the carburetor through the drain tube into the approved gasoline-storage container.

7. Once the fuel has drained, tighten the drain screw with the screwdriver.

NOTE: Make sure to drain your carburetor before storing the generator for long periods of time.

8. Reinstall the service panel.

DRAINING/CHANGING OIL

Change the oil according to the Recommended Maintenance Schedule.

Change the oil MORE OFTEN if operating under heavy load or high ambient temperatures. It is also necessary to drain the oil from the crankcase if it has become contaminated with water or dirt. Changing the oil when the engine is warm allows for complete drainage.

To change engine oil:

1. With the help of another person, place the generator on an elevated platform such as table or workbench.

NOTE: To avoid possible oil spills from the carburetor bowl, drain the carburetor before draining oil.

2. Turn oil access cover knob clockwise, and remove the cover from the side panel.

3. Place a suitable container underneath the generator to catch the used oil.

4. Pull out the oil drain tube.

5. Remove the oil drain plug to allow the oil drain completely.

6. Reinstall the oil drain plug after the oil has drained.

NOTE: Never dispose of used engine oil in the trash or down a drain. Please call a local recycling center or auto garage to arrange proper oil disposal.

7. With the generator in a level position and refill with engine oil following the instructions in the Checking/Adding engine oil section previously in this manual.

8. Reinstall the oil dipstick and tighten it securely. Wipe clean any oil spillage and reinstall the oil access cover.

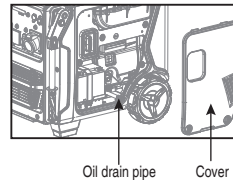

TRANSPORTATION & STORAGE

WARNING



Before attempting to service or troubleshoot the generator, the owner or service technician must first read the owner's manual and understand and follow all safety instructions. Failure to follow all instructions may result in conditions that can lead to voiding of the EPA certification or product warranty, serious personal injury, property damage or even death.

TRANSPORTING THE GENERATOR

To prevent fuel spillage when transporting, be sure to perform the following:

1. Tighten the fuel cap and turn the vacuum relief valve to "OFF".
2. Set the engine switch to "OFF".
3. Drain the fuel tank if possible.
4. Keep the generator upright. Never place the generator on its side or upside down - doing so will make it difficult to start.



WARNING: Avoid direct sunlight inside a vehicle. If the generator is left in an enclosed vehicle for many hours, the high temperature could cause the fuel to vaporize and result in a possible explosion.

STORING THE GENERATOR

Shut off the generator and allow the unit to cool to room temperature before storing it. NEVER place any type of storage cover on the generator while it is still hot. Do not obstruct any ventilation openings.

Follow the procedures below for properly storing your generator. We highly recommend running your generator once a month for 20 to 30 minutes. Plug in a small load in to ensure there is proper power output.

For Short Periods (30 to 60 Days):

- Drain the carburetor.
- Disconnect the negative lead from the battery.
- **Add fuel stabilizer:**

Follow the suggested portions and instructions of your preferred stabilizer. Run the engine for 15 to 20 minutes, allowing the fuel stabilizer to mix with the gasoline and circulate through the carburetor, and then top off with fuel. Filling the fuel tank full reduces the amount of air in the tank and helps fight deterioration of fuel.

For Extended Periods (Over 60 Days):

- Disconnect the negative lead from the battery.
- Drain the fuel tank and carburetor (see "DRAINING THE FUEL TANK"). NEVER store generator with fuel in the tank for more than two months.
- Change the engine oil (see "CHANGING OIL").



WARNING: Store the generator upright in a cool and dry location, away from sources of heat, open flames, sparks or pilot lights.

PRODUCT DISPOSAL

Do not dispose of used generator or parts with your household waste. This product contains electrical or electronic components that should be recycled. Please take this product to your local recycling facility for responsible disposal to minimize its environmental impact.

Do not dispose of used oil or fuel in the trash or down a drain. Please contact your local recycling center or auto garage to arrange proper oil/fuel disposal.

TROUBLESHOOTING GUIDE

ENGINE WILL NOT START

Possible Cause	Solution
Battery not charged.	Charge battery.
Engine switch is in the OFF position.	Turn engine switch to the ON position.
No fuel.	Fill fuel tank.
Stale gasoline or water in gasoline.	Drain entire system and refill with fresh fuel.
Engine oil level is low.	Engine is equipped with Low Oil Shutoff. If engine oil level is low, it must be filled before unit will start. Check engine oil level and fill, if necessary.
Fuel-switch is in OFF position.	Turn fuel-switch to the ON position.
Spark plug faulty, fouled, or improperly gapped.	Replace spark plug.
Engine stored without treating or draining gasoline, or refueled with bad gasoline.	Drain fuel. Refuel with fresh gasoline.
Dirty fuel filter.	Replace fuel filter or contact a qualified service center.

ENGINE LACKS POWER.

Possible Cause	Solution
Dirty air filter.	Check air filter element. Clean or replace as needed.
Engine stored without treating or draining gasoline, or refueled with bad gasoline.	Drain fuel. Refuel with fresh gasoline. If problem continues, contact a qualified service center.

AC RECEPTACLE DOES NOT WORK.

Possible Cause	Solution
OUTPUT indicator is OFF, and OVERLOAD indicator is ON.	Check AC load. Stop and restart the engine. Check the cooling air inlet. Stop and restart the engine.
AC Circuit protector(s) tripped.	Check AC load and reset AC circuit protector(s)
Item plugged in is defective.	Try a different item.

If problem persists after trying the above solutions, contact your nearest authorized service center for assistance.

SPECIFICATIONS

Item	8.5kW	Inverter Generator	10kW
Type	Inverter Generator		
Rated frequency (Hz)	50/60		
Rated voltage (V)	110/120/220/230/240	380/400/415	110/120/220/230/240 380/400/415
Rated watts (kW)	8.5		10
Starting watts (kW)	9.3		11
Power factor	1		
Overload Protect (DC)	Non-fuse Protector		
Phase	Single	Three	Single Three
Engine	550VIE		
Engine type	Single cylinder, 4-Stroke, forced air cooling, OHV		
Displacement (cc)	550		
Fuel type	Unleaded Gasoline		
Fuel tank capacity (L)	32		
Continue Running Time at rated power (h)	5		
(Oil Capacity (L)	1.4		
Spark Model No.	F7RTC		
Starting mode	Recoil/Electric		
Generator set	Length×Width×Height (mm) 680×670×770		

